

LeverMount®

	Model T66	Units	Model 350i
	Load Cell Specification		Load Cell Specification
Load Cell Approval	3000 divisions (c3)		3000 divisions (C3)
	OIML R60 Class C		OIML R60 Class C
Load Ranges	20,50,100 & 200	kg	300, 500, 1000, 2000, 3000, 5000
Rated Output	2mV/V+/- 0.1%	mV/V ±0.25%	2(±0.15)
Combined Error	<±0.017	%*	<±0.017
Non-repeatability	<±0.015	%*	<±0.015
Creep (30 minutes)	<±0.016	%*	<±0.016
Temp Effect on Zero Balance	<±0.01	%*°C	<±0.01
Temp Effect on Span	<±0.006	%*°C	<±0.006
Compensated Temp Range	-10 to +40	°C	-10 to +40
Operating Temp Range	-20 to +70	°C	-20 to +70
Safe Overload	150	%*	150
Ultimate Overload	300	%*	300
Zero Balance	<±1	%*	<±2
Input Resistance	400±20	ohms	400±20
Output Resistance	350±3	ohms	350±3
Insulation Resistance	>5000	Mohms @ 100V.dc	>5000
Recommended Supply Voltage	10	V	10
Maximum Supply Voltage	15	V	15
Cable Length	3		5
Protection Class	IP68		IP68

**With respect to rated output*

Shipping Weights: (kg)
 300, 500, 1000, 2000 = 4 kg
 3000, 5000 = 9 kg.

Construction
 Mount manufactured from cast 316 stainless steel.
 Load cell manufactured from high strength stainless steel, electro-polished, fully welded and sealed to IP68.

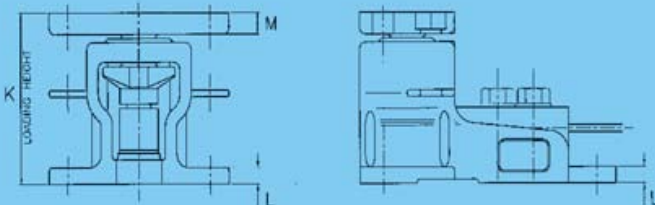
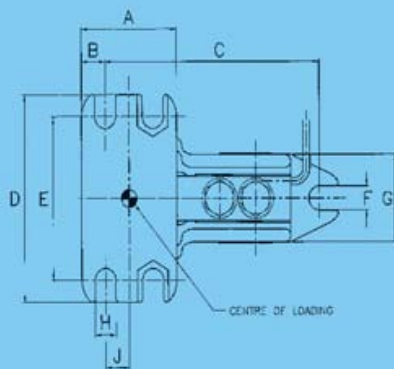

Capacity (kg)	A	B	C	D	E	F	G	H	J	K	L	M
300, 500, 1000, 2000	70	16	168	132	108	14	60	14	19	110	12	12
3000, 5000	100	25	225	190	150	22	80	22	25	164	15	20

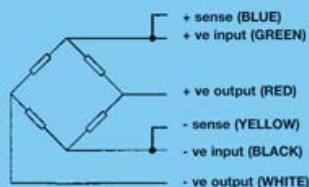

Electrical Connections
 *Via 6 core, 7/0.2mm (0.22mm²), screened pvc cable.

In all cases screen is not connected electrically to the load cell.

UK Patent No. 2 339 026
 US Patent No. 6 320 142

Our policy is one of continuous product enhancement. We therefore reserve the right to incorporate technical modifications without prior notification. LeverMount® is a registered trade mark of Thames Side-Sensors Limited.

Distributed by



Thames Side Sensors Ltd

Unit 10, io Trade Centre, Deacon Way,
 Reading, Berkshire RG30 6AZ
 tel: +44 (0) 118 941 1387 fax: +44 (0) 118 941 2004
 e-mail: sales@thames-side.co.uk
 web: www.thames-side.com

LeverMount®

Unique, patented and cost effective solution for process weighing applications

*capacities 20kg, 50kg, 100kg, 200kg, 300kg, 500kg
1000kg, 2000kg, 3000kg and 5000kg*



purpose designed stainless load cell and mount arrangement

LeverMount® can be raised and lowered under load without jacking

load cell removal without jacking or dummies

straightforward, low cost installation without specialist tooling

highly stable three point mounting

substantial lift off prevention

easily configurable for radial or tangential mounting

substantial lift off prevention

allows for vessel expansion and contraction

stainless steel OIML C3 approved load cell, fully welded, sealed to IP68

LeverMount® is the latest development in load cell weighing assemblies from Thames Side Sensors. Process weighing installations are made easier, safer and more cost effective using this simple, innovative design.

Load cells approved to 3000 divisions OIML R60 Class C.

Load cells available in ATEX approved versions for hazardous area applications.



LeverMount® - Innovation from Thames Side-Sensors Ltd

The concept of a purpose designed loading assembly using single ended shear beam load cells for vessel weighing was first introduced in the early 1980's. LeverMount® is the next generation of load cell weighing assemblies, purpose designed to offer a completely fresh approach to process weighing solutions utilising the established Thames Side range of shear beam and bending beam load cells. LeverMount® retains the advantages of existing mounts, whilst providing improved mechanical stability before and during installation. LeverMount® can be raised or lowered under load without specialised tools; additionally, the load cell can be removed or replaced without the need for jacking or dummies.



UNIQUENESS & SIMPLICITY

Many existing mounting assemblies provide a jacking feature which allows a vessel to be supported by the mounts prior to the installation of the load cells. Typically, the mounts will initially be fitted in a fully jacked condition; this avoids the risk of damage to the load cell, either as a result of physical abuse, or as a consequence of arc welding or other mechanical activity.

Once the vessel is secured in position, the load cell is installed, and the top plate of the mount is then jacked down onto the load button, making the system live.

The tried and tested method of jacking a mount is by means of one or more threaded support pillars which engage with the top plate of the mount. This arrangement works to best advantage when the load applied to the mount is small - often when the vessel is empty. Under other load conditions, an external jack is usually employed to raise and lower the vessel in order to avoid overloading the support pillars.

LeverMount's® unique design is such that no separate support arrangements are necessary to raise and lower the vessel. The base casting itself provides a stable load-bearing platform prior to installation of the load cell. Once the vessel is in position and the two transit bolts are removed, the load cell is then used as a lever to raise the top plate of the mount into the working position, whether the vessel is empty or full.

Removal of a load cell at any time is accomplished by reversing the procedure, and requires no specialist tools. Installation, operation and maintenance of the vessel weighing system is consequently made safer, easier, swifter and less costly.

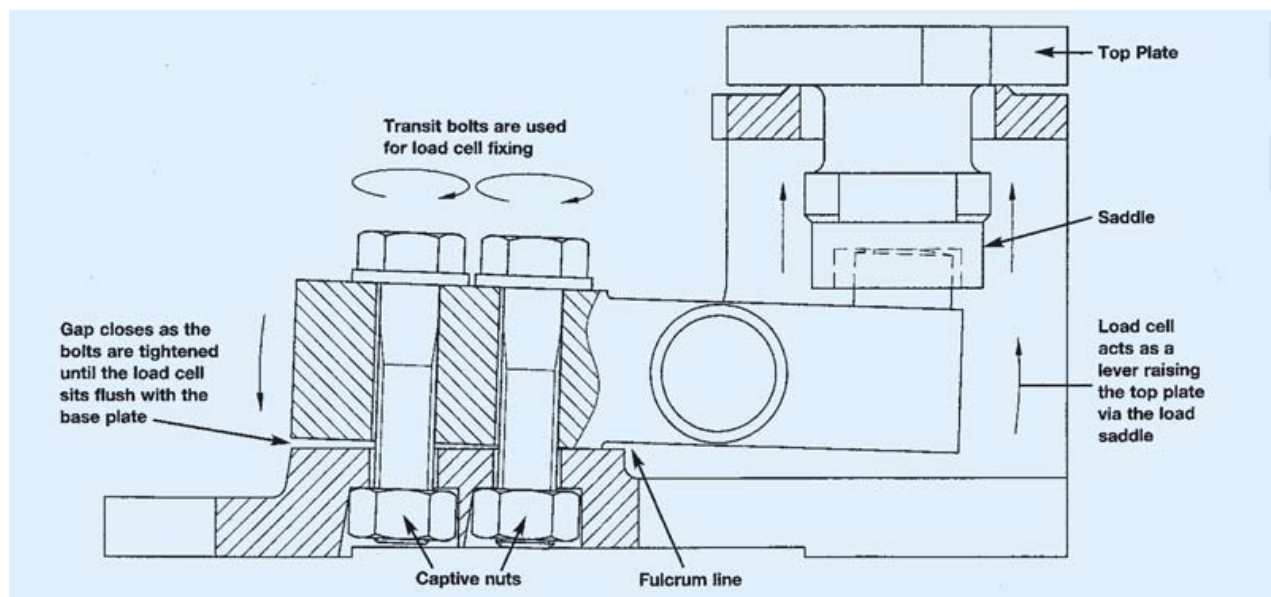

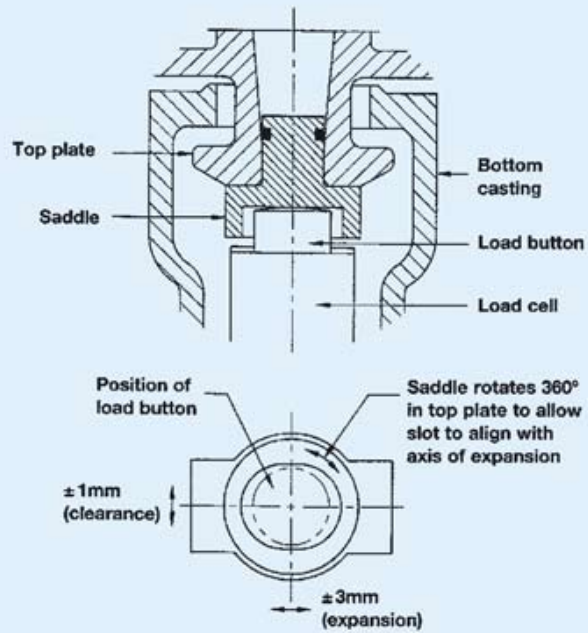
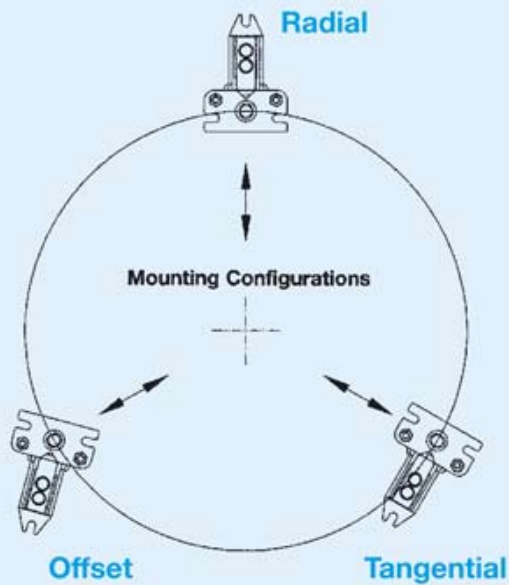

FEATURES

- Purpose designed cast steel mount and stainless steel load cell
- Simple two part casting using the transit bolts into captivated nuts for load cell fixing
- Stainless steel, IP68, fully welded, single ended shear beam load cell
- Load cell acts as the lever to raise and lower the top plate and vessel
- Vessel can be raised and lowered under load
- No jacking screws or support pillars
- Three point support and fixing
- Top plate movement in the x, y and rotational axis
- Configurable for radial, tangential or offset mounting
- Substantial anti-lift facility
- Nominal difference between the working height and the installed height
- Load cell can be easily removed under load in situ
- Two designs cover the range from 300kg to 5000kg

BENEFITS

- Ideal for process weighing applications that require an accurate, safe and cost effective solution
- Aesthetically pleasing design, eliminating the need for additional machining and special bolts
- Suitable for use in the harshest of industrial environments
- No need for alternative lifting devices such as pad jacks
- Easier, quicker and safer than alternative mount arrangements
- No stripped threads or top plate interference
- Eliminates rocking and twisting in the mount, always finds a plane
- Tolerant of steel work misalignment; allows the vessel to breathe avoiding any mechanically induced errors
- Easy alignment to the radial axis of the vessel
- Increased safety
- Reduces the need to adjust for pipe work without flexible connections
- Less down time
- Covers the majority of process weighing applications

