

Single Point Aluminum Load Cell



FEATURES

- Capacity range: 3 - 200kg
- Only 22 mm high
- Aluminum construction
- Single point 350 x 350mm platform
- IP66 protection
- OIML R60 and NTEP approved

OPTIONAL FEATURES

- EEx ia IIC T4 - ATEX hazardous area approval
- FM approval
- Symmetric configuration available

DESCRIPTION

Model 1022 is a low profile single point load cell designed for direct mounting in low cost weighing platforms.

Its small physical size, combined with high accuracy and aluminum construction, makes this low cost load cell ideally suited for retail, bench and counting scales.

Using 1022 load cells simplifies scale construction, which results in significant parts and labor savings.

Available in a range of capacities, from 3 to 200kg and approved to OIML R60 (4000d) or NTEP (5000d, single). Environmental protection to IP66 is provided as standard. For hazardous environments, ATEX EEx ia IIC T4 approved versions are available.

APPLICATIONS

- Bench scales
- Counting scales
- Grocery scales

OUTLINE DIMENSIONS in mm

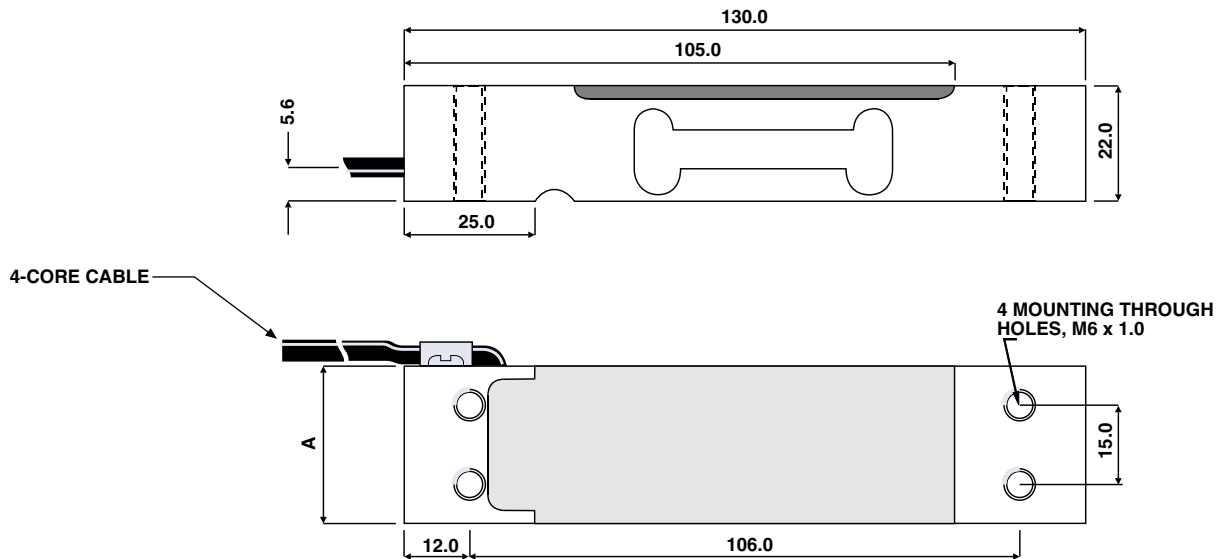

CAPACITY	A
3, 5, 7kg	25.4
10, 15, 20, 30kg	30.0
35 - 200kg	40.0

SPECIFICATIONS

PARAMETER	VALUE				UNIT
Rated capacity-R.C. (E_{max})	3, 5, 7, 10, 15, 20, 30, 35, 50, 100, 150, 200***				kg
NTEP/OIML Accuracy class	NTEP	Non-Approved	C3*	C4	
Maximum no. of intervals (n)	5000 single**	1000	3000	4000	
$Y = E_{max}/V_{min}$	15000	3333	10000	10000	Maximum available
Rated output-R.O.	2.0				mV/V
Rated output tolerance	0.2				±mV/V
Zero balance	0.2				+mV/V
Zero Return, 30 min.	0.0330	0.0300	0.0170	0.0125	±% of applied load
Total Error (per OIML R60)	0.0200	0.0500	0.0200	0.0150	±% of rated output
Temperature effect on zero	0.0023	0.0100	0.0023	0.0014	±% of rated output/°C
Temperature effect on output	0.0010	0.0030	0.0010	0.00075	±% of applied load/°C
Eccentric loading error	0.0057	0.0085	0.0057	0.0042	±% of rated load/cm
Temperature range, compensated	-10 to +40				°C
Temperature range, safe	-20 to +70				°C
Maximum safe central overload	150				% of R.C.
Ultimate central overload	300				% of R.C.
Excitation, recommended	10				Vdc or Vac rms
Excitation, maximum	15				Vdc or Vac rms
Input impedance	415±15				Ohms
Output impedance	350±3				Ohms
Insulation resistance	>2000				Mega-Ohms
Cable length	0.5				m
Cable type	4 wire, PVC, single floating screen				Standard
Construction	Aluminum				
Environmental protection	IP66				
Platform size (max)	350 x 350				mm
Recommended torque	Up to 30kg: 7.0 35kg & up: 10.0				N*m

* 50% utilization

** Also available at 50% utilization

*** 150-200kg are not approved by NTEP, 200kg is not approved by OIML

**WIRING SCHEMATIC DIAGRAM
(UNBALANCED BRIDGE CONFIGURATION)**

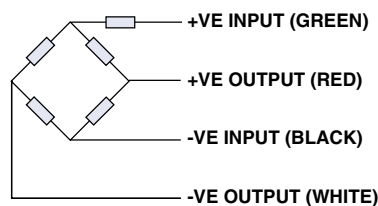
VISHAY TRANSDUCERS (VT) SALES OFFICES

VT Americas
City of Industry, CA
PH: +1-626-858-8899
FAX: +1-626-332-3418
vt.us@vishaymg.com

VT Netherlands
Breda
PH: +31-76-548-0700
FAX: +31-76-541-2854
vt.nl@vishaymg.com

VMG UK
Basingstoke
PH: +44-125-646-2131
FAX: +44-125-647-1441
vt.uk@vishaymg.com

VMG Israel
Netanya
PH: +972-9-863-8888
FAX: +972-9-863-8800
vt.il@vishaymg.com

VMG Germany
Heilbronn
PH: +49-7131-3901-260
FAX: +49-7131-3901-2666
vt.de@vishaymg.com

VT China
Tianjin
PH: +86-22-2835-3503
FAX: +86-22-2835-7261
vt.prc@vishaymg.com

VMG France
Chartres
PH: +33-2-37-33-31-20
FAX: +33-2-37-33-31-29
vt.fr@vishaymg.com

VT Taiwan*
Taipei
PH: +886-2-2696-0168
FAX: +886-2-2696-4965
vt.roc@vishaymg.com
*Asia except China



Disclaimer

All product specifications and data are subject to change without notice.

Vishay Intertechnology, Inc., its affiliates, agents, and employees, and all persons acting on its or their behalf (collectively, "Vishay"), disclaim any and all liability for any errors, inaccuracies or incompleteness contained herein or in any other disclosure relating to any product.

Vishay disclaims any and all liability arising out of the use or application of any product described herein or of any information provided herein to the maximum extent permitted by law. The product specifications do not expand or otherwise modify Vishay's terms and conditions of purchase, including but not limited to the warranty expressed therein, which apply to these products.

No license, express or implied, by estoppel or otherwise, to any intellectual property rights is granted by this document or by any conduct of Vishay.

The products shown herein are not designed for use in medical, life-saving, or life-sustaining applications unless otherwise expressly indicated. Customers using or selling Vishay products not expressly indicated for use in such applications do so entirely at their own risk and agree to fully indemnify Vishay for any damages arising or resulting from such use or sale. Please contact authorized Vishay personnel to obtain written terms and conditions regarding products designed for such applications.

Product names and markings noted herein may be trademarks of their respective owners.